

HI 1756-WS SINGLE CHANNEL WEIGH SCALE

REV.	ECO/DDC	DESCRIPTION	DATE	DRAFT	CHECK	APV'D
A	----	RELEASED	09-15-00	V.J.C.	S.N.	M.A.S.
B	11184	REVISED PER ECN.	09-14-12	V.J.C.	C.B.	V.J.C.
C	11911	REVISED PER ECN.	05-04-17	V.J.C.	L.E.G.	V.J.C.

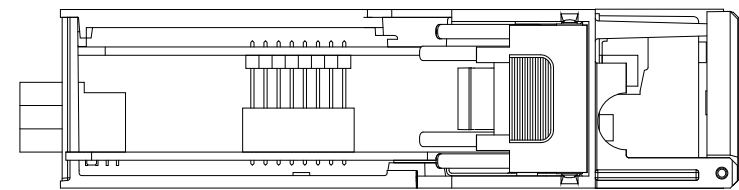
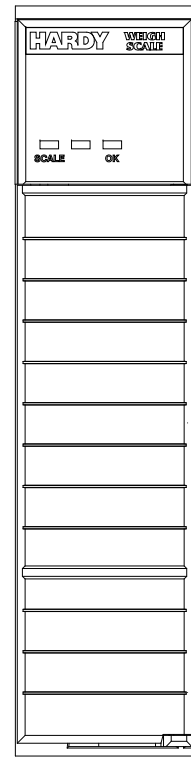
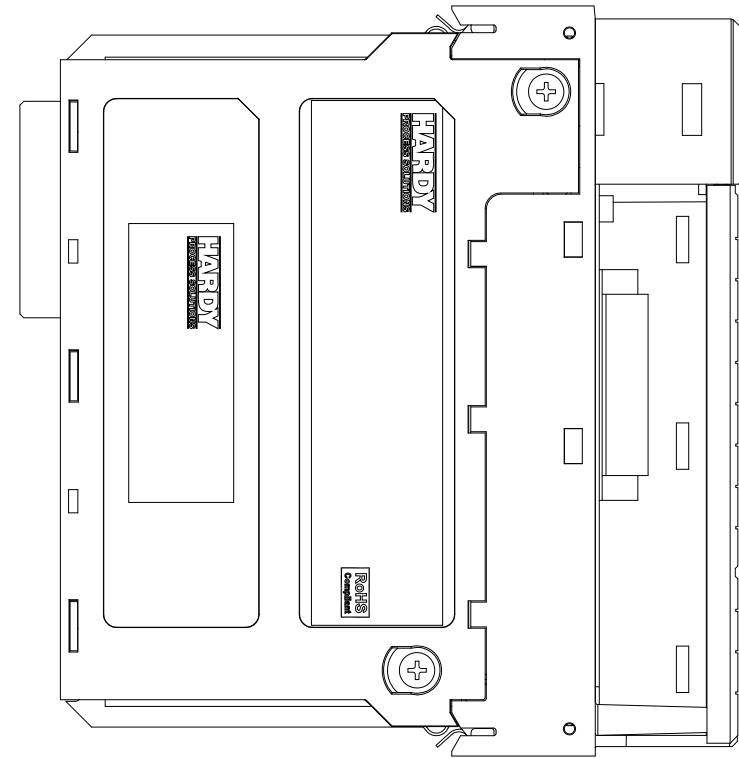

3. SEE SHEET 3 FOR REMOTE TERMINATION ASSEMBLY AND INTERFACE CABLE OPTIONS.
2. SEE SHEET 2 FOR WEIGH SCALE INTERFACE CONNECTOR PIN DESIGNATIONS.
1. SEE 0596-0247-01 USER'S GUIDE FOR ADDITIONAL INFORMATION.

NOTES: UNLESS OTHERWISE SPECIFIED

PROPRIETARY NOTICE
 ALL DATA AND INFORMATION CONTAINED IN OR DISCLOSED BY THIS DOCUMENT IS CONFIDENTIAL AND PROPRIETARY INFORMATION OF HARDY PROCESS SOLUTIONS INC. AND ALL RIGHTS THEREIN ARE EXPRESSLY RESERVED. BY ACCEPTING THIS MATERIAL THE RECIPIENT AGREES THAT THIS MATERIAL AND THE INFORMATION CONTAINED THEREIN IS HELD IN CONFIDENCE AND IN TRUST AND SHALL NOT BE USED, COPIED, REPRODUCED IN WHOLE OR IN PART, NOR ITS CONTENTS REVEALED IN ANY MANNER TO OTHERS, EXCEPT TO MEET THE SPECIFIC PURPOSE FOR WHICH IT WAS DELIVERED.

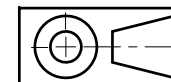

ITEM	QTY	PART NUMBER	DESCRIPTION	COMMENTS
		0584-0043	I/I DIAGRAM, WEIGH SCALE, HI 1756-WS, SINGLE CHANNEL	
PARTS LIST				
UNLESS OTHERWISE SPECIFIED DIMENSIONS ARE IN INCHES TOLERANCES ARE: FRACTIONS: N/A DECIMALS: .XX = ±.03 .XXX = ±.010 ANGLES: ±0°, 30'		CONTRACT NO.		 HARDY PROCESS SOLUTIONS
MATERIAL		APPROVALS		
		DRAWN V. CHULA	DATE 09-15-00	
FINISH		CHECKED S. NAVARRO	DATE 09-15-00	
		APPROVED M. STRAUCH	DATE 09-15-00	
		ISSUED K. McNULTY	DATE 09-15-00	
DO NOT SCALE DRAWING		PRODUCTION	DATE	
		SIZE D	FSCM 21316	DRAWING NO. 0584-0043
		REV. C		FILE NAME: 584043C1.DWG
		SCALE: NONE		SHEET 1 OF 3

NOTES:

1. IF CONDUIT IS USED, DO NOT RUN LOAD CELL CABLE PARALLEL TO, OR IN SAME CONDUIT WITH, POWER WIRING, RELAY CABLE OR OTHER HIGH ENERGY CABLES.
2.  FACTORY INSTALLED JUMPERS TO REMAIN IN PLACE ONLY FOR FOUR WIRE NON C2 LOAD CELL CONNECTION. JUMPERS TO BE REMOVED FOR SIX WIRE NON C2 OR EIGHT WIRE C2 LOAD CELL CONNECTIONS. EXCITATION AND SENSE WIRES TO BE CONNECTED TOGETHER IN JUNCTION BOX.
3. REQUIRED LOAD CELL CABLE FOR C2 SECOND GENERATION CALIBRATION SYSTEM AND INTEGRATED TECHNICIAN: HARDY PROCESS SOLUTIONS P/N 6020-0001.
4. SEE 0596-0247-01 USER'S GUIDE FOR ADDITIONAL INFORMATION ON LOAD CELL CONNECTIONS.
5. TERMINAL BLOCK WIRE SIZE RANGE: 22 AWG MIN / 16 AWG MAX. WIRE TIGHTENING TORQUE: 2 LB-IN MINIMUM / 4 LB-IN MAXIMUM.
6. FOR CLARITY, ONLY ONE LOAD SENSOR CONNECTION IS SHOWN.

HI 1756-WS SINGLE CHANNEL WEIGH SCALE CONNECTOR WIRING

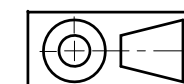
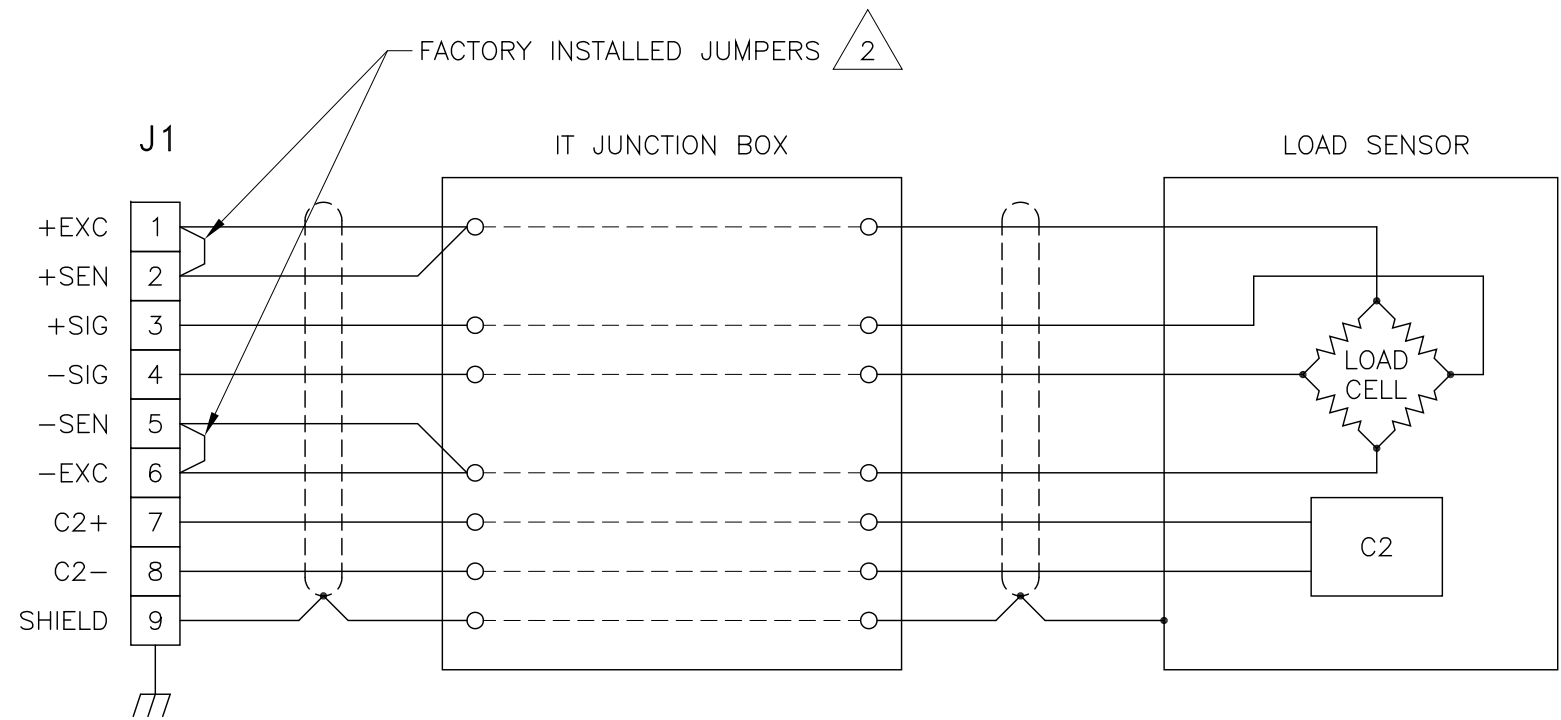
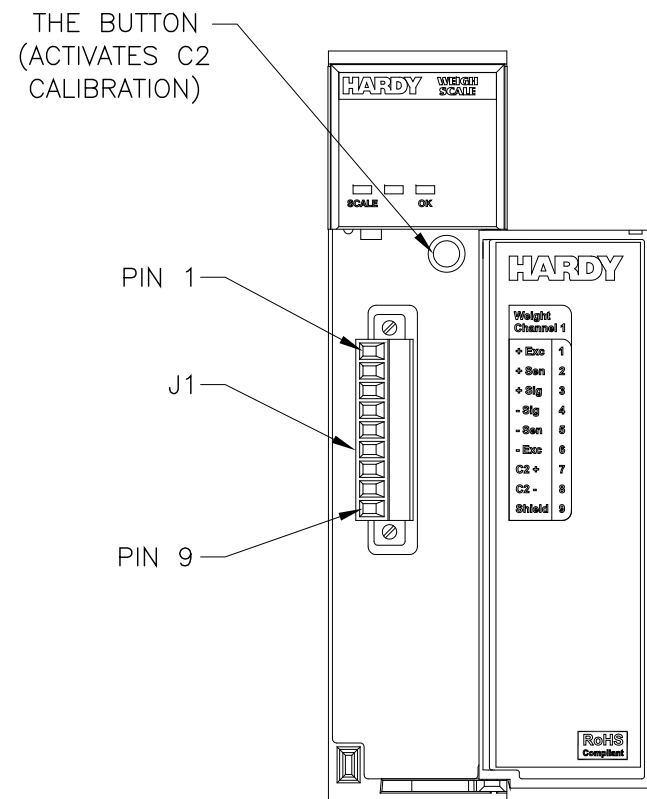

HARDY PROCESS SOLUTIONS			
TITLE I/I DIAGRAM, WEIGH SCALE, HI 1756-WS, SINGLE CHANNEL			
SIZE	FSCM	DRAWING NO.	REV.
D	21316	0584-0043	C
FILE NAME: 584043C1.DWG		SCALE: NONE	SHEET 2 OF 3

NOTES:

1. IF CONDUIT IS USED, DO NOT RUN LOAD CELL CABLE PARALLEL TO, OR IN SAME CONDUIT WITH, POWER WIRING, RELAY CABLE OR OTHER HIGH ENERGY CABLES.
2. REQUIRED LOAD CELL CABLE FOR C2 SECOND GENERATION CALIBRATION SYSTEM AND INTEGRATED TECHNICIAN: HARDY INSTRUMENTS P/N 6020-0001.
3. SEE 0596-0247-01 USER'S GUIDE FOR ADDITIONAL INFORMATION ON LOAD CELL CONNECTIONS.
4. TERMINAL BLOCK WIRE SIZE RANGE: 22 AWG MIN / 14 AWG MAX. WIRE TIGHTENING TORQUE: 2 LB-IN MINIMUM / 4 LB-IN MAXIMUM.

HI 1756-WS REMOTE TERMINATION (OPTION RTA)

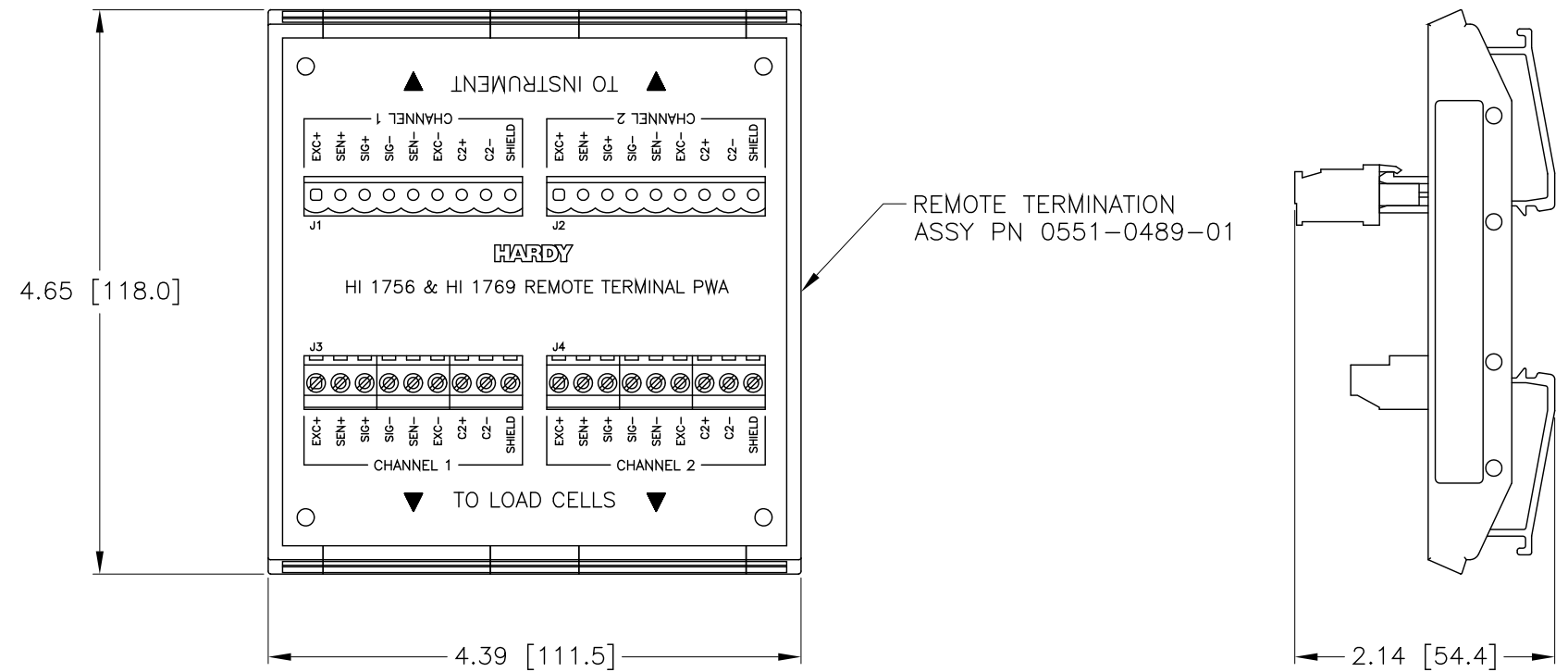

HI 1756-WS REMOTE TERMINATION CABLE (OPTION C6)

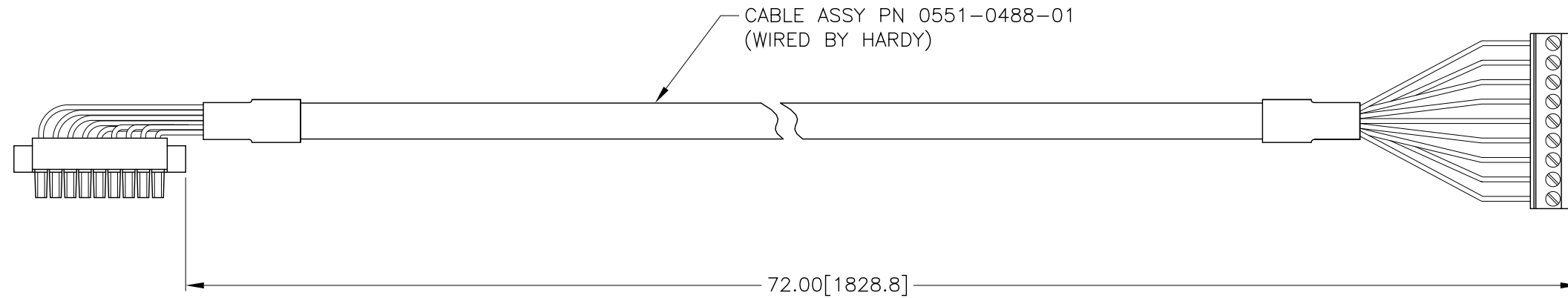

DIMENSIONS IN INCHES [MM]

HARDY PROCESS SOLUTIONS			
TITLE I/I DIAGRAM, WEIGH SCALE, HI 1756-WS, SINGLE CHANNEL			
SIZE	FSCM	DRAWING NO.	REV.
D	21316	0584-0043	C
FILE NAME: 584043C1.DWG		SCALE: NONE	SHEET 3 OF 3

